

**εκο
οκπα**

SAFEHOME





SAFEHOME

A fence is not only a way to ensure safety and privacy, but above all to crown the investment of building a house. We offer high quality, complete fences-panels, gates and wickets. Everything in a dozen or so original patterns, refined in every detail. Each of our fence panels can have a classic, simple or more complex shape.

Standard, Elegance and Prestige - we offer fences made in three styles, thanks to which the customer can easily choose the one that perfectly matches the surroundings. What is more, fences can be manufactured in any of the color from the palettes we offer. An additional advantage is the possibility of creating an individual project, adapted to the terrain.

Regardless of the appearance and shape of the panel, all our fences have one thing in common - a solid construction. All of its elements are made of galvanized steel. This, in turn, provides excellent corrosion protection. The order fulfillment time remains unchanged and ranges from 4 to 8 weeks, depending on the project specification. It is the shortest lead time on the market.

WHY IS IT WORTH TO BUY OUR FENCES?



DURABILITY

We produce Safe Home fences based on the highest quality materials and the latest technologies. Each element is protected with a layer of zinc, which is an excellent anti-corrosion protection. In addition, the steel element is powder-painted in the selected color. All of the above are confirmed by a 5-year warranty, which gives you not only the certainty of anti-corrosion protection, but also high-quality welds.



SECURITY

The indicator of security of any fence is undoubtedly a solid gate. You can choose between turn-out and sliding gates. The first solution is a guarantee of solid fastening, durable locking while maintaining the simplicity of use. The gate leaves open sideways. If you want to save space on the driveway, we recommend sliding gates that move along rails along the fence.

STEEL
ELEMENT

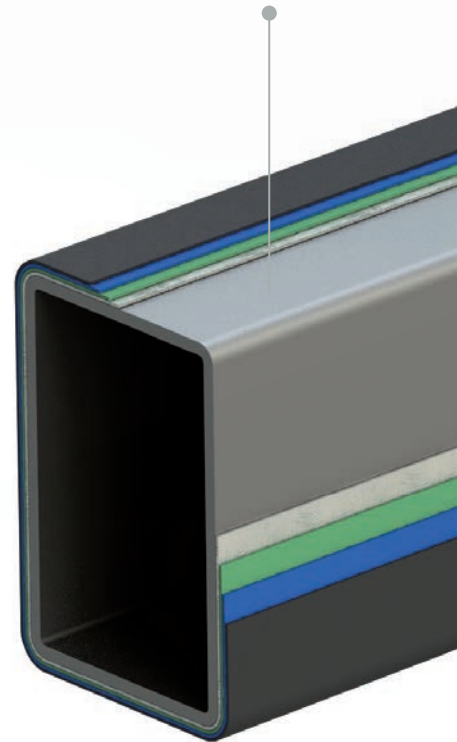

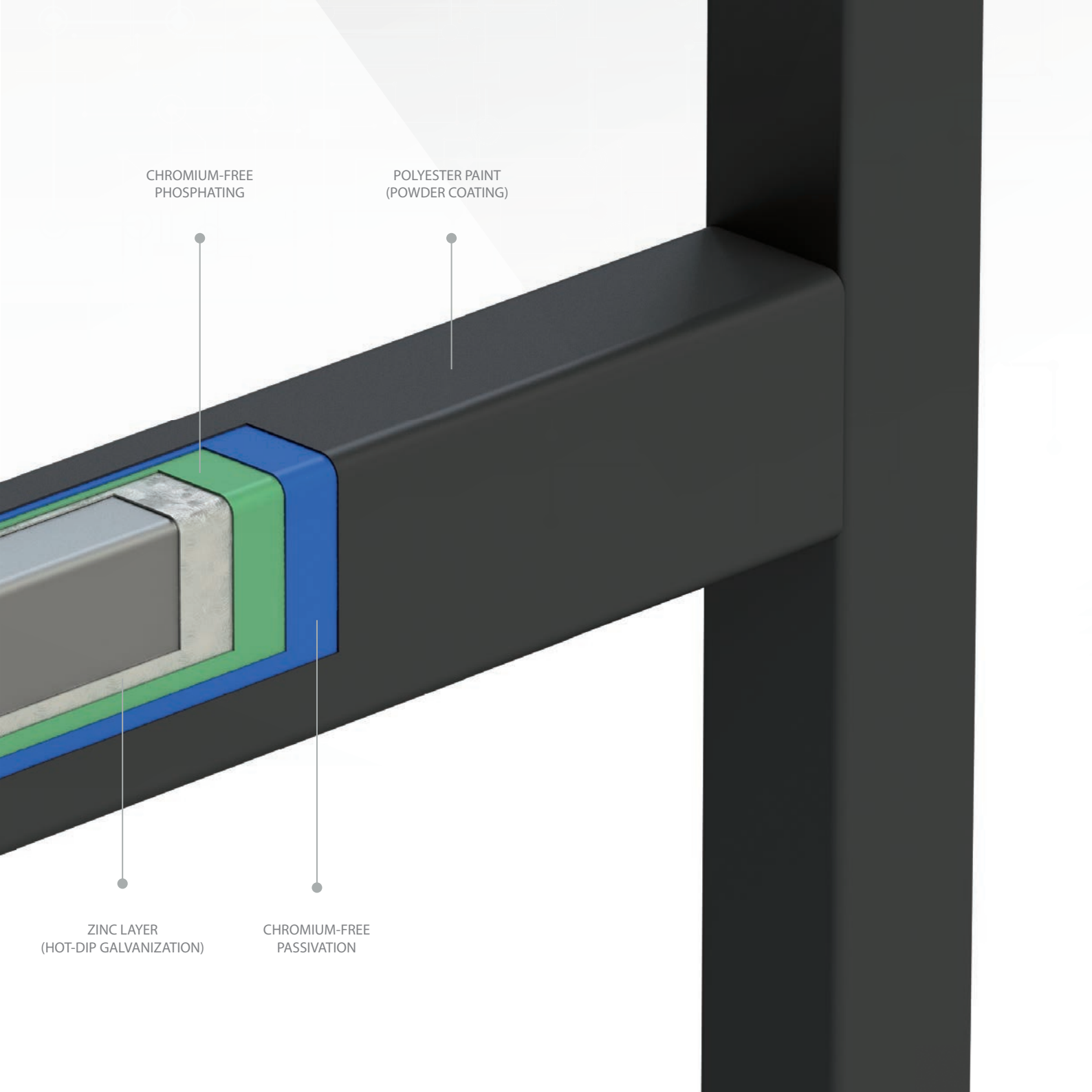

CHROMIUM-FREE
PHOSPHATING

POLYESTER PAINT
(POWDER COATING)

ZINC LAYER
(HOT-DIP GALVANIZATION)

CHROMIUM-FREE
PASSIVATION



INDIVIDUALISM

Individual designs adapted to the appearance of user's requirements and terrain. Knowledge and experience in the production of fences allows us to create a project that will fully meet your needs. Panels, gates and wickets can be attached to steel posts or masonry posts. Depending on the needs, the fence can also be mounted on the foundation.



CONTROL

After equipping the gate with the motor and connecting it to the control devices, it can become a part of the „Smart Home“. The customer chooses the products, and we will refine all the automation elements in which they are to be equipped. Motors, transmitters and control units are part of the „All in One Control“ product line. All in One Control means the freedom to control not only the gate, but also blinds, doors, alarms and even lighting. Reaching for products from the „All in One Control“ product line, customers are assured of complete technological compliance.



ORDER TRANSPORT

Having regard to the quick delivery of your orders, we have created our own fleet of trucks. Currently, we own 240 vehicles. Each of them is equipped with a forklift, so that in addition to transport, we also offer you unloading the order. In response to your needs, each of our vehicles has been equipped with a payment terminal, so that customers can pay for the order directly from the driver.



EVERYTHING FOR THE HOME

Years of experience, qualified staff, modern machine park, the ability to respond to the market needs have allowed us to create a complete range of window and door joinery. We already offer windows, doors, gates, blinds, sliding systems, façade systems, mosquito nets, facade blinds and all types of complementary accessories. Now, together with the joinery, you can also receive a fence with one transport.



FUNCTIONALITY

The safety of use and functionality will be provided by accessories that can be used to complement our fences. The gates can be equipped with a signal lamp or a drive that will allow it to be controlled by a remote control. A letterbox or house number can be installed in the selected spot on the fence. We also highly recommend the wicket with an intercom. This element will not only increase the security of communication with people behind the fence, but also allow you to open the gate without leaving your home.



HIGHEST QUALITY

Our products are made out of the components from reliable suppliers. Attention to every detail and the highest quality of the product - these are the goals that guide us in our everyday work. The accuracy with which our fences are made is a guarantee of quality and unchanged appearance for many years.

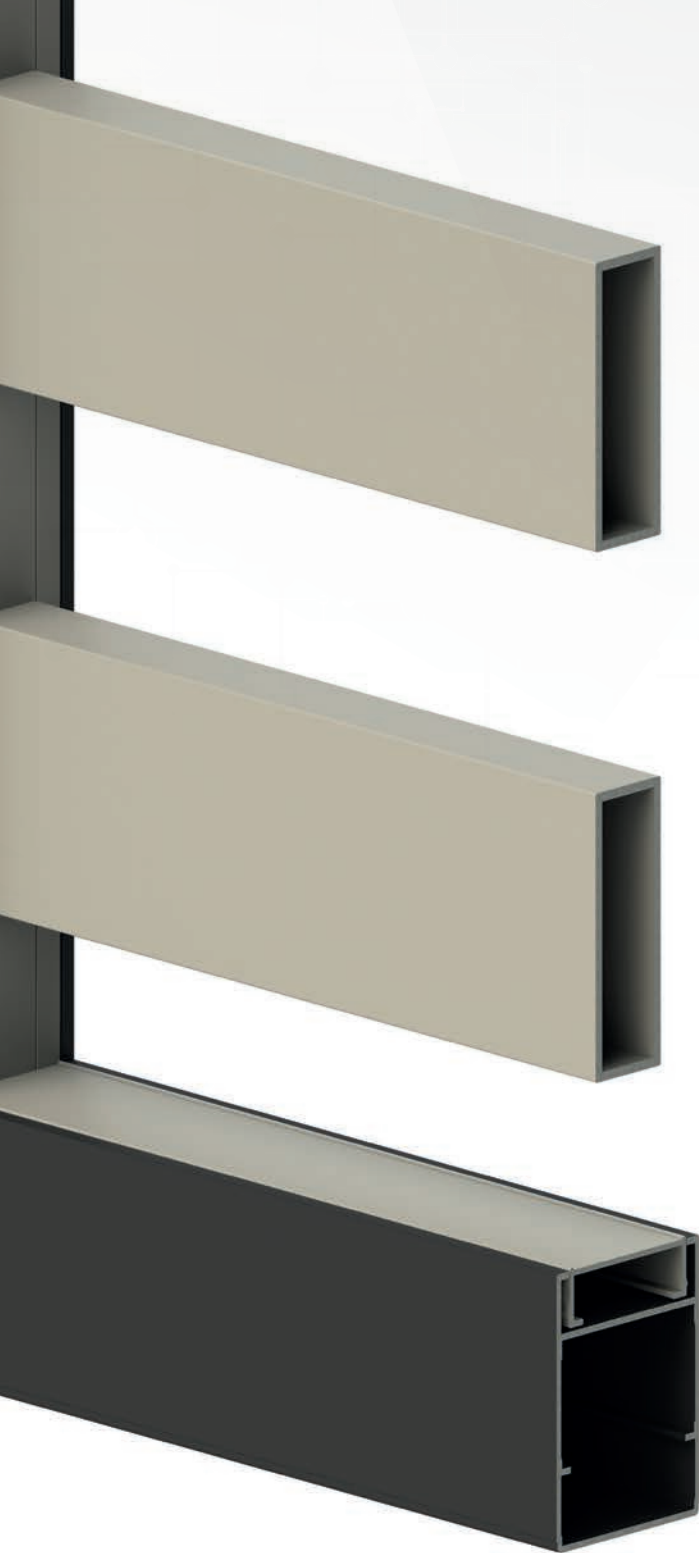

ALUMINIUM FENCES

Spans, gates and wickets made of aluminum profiles are durable and functional elements of fences. The profile joining system is made by the method of screw connections - thus we have eliminated the need to weld aluminum - no visible welds. Such connection additionally allows to make a fence in a two-color or multi-color variant.

These features make the aluminum fence look aesthetically.

The use of aluminum profiles also allows for free shaping of the appearance of the fence elements. Our production capabilities are very extensive, which is why we offer our clients various variants of fencing:

- *Profiles of different widths (from 20 to 120 mm) allow for the construction of openwork spans with any clearance, you can combine profiles of different widths and choose different widths of the clearance,*
- *Panel variant - fulfilling without gaps,*
- *Combined variant – panel and openwork are mounted in one span, in any proportion.*

MOUNTING PLATE

To make the installation of our sliding gates as simple as possible, we deliver a mounting plate with the sliding gate, on which there are already mounted poles and a trolley as well as a prepared place for mounting the drive. Such a solution results in shortening the assembly time and ensuring its accuracy.

MAXIMUM DIMENSIONS

Due to legal requirements as well as technological and transport limitations, we produce fences in the following dimensions:

1. **Sliding gates** – maximum dimensions:

- Steel gates – 5200 x 2000* mm,
- Aluminum gates – 5000 x 2000* mm.

2. **Double-leaf gates** - maximum dimensions:

- Steel gates – 6000 x 2000* mm,
- Aluminum gates – 4000 x 2000* mm,
- Wickets – minimum width 900 mm, height up to 2000 mm,
- Spans – maximum dimensions 2500 x 2000 mm.

* Some fencing designs require special reinforcements for larger dimensions. The possibility of making a fence with dimensions exceeding the maximum are to be agreed individually.

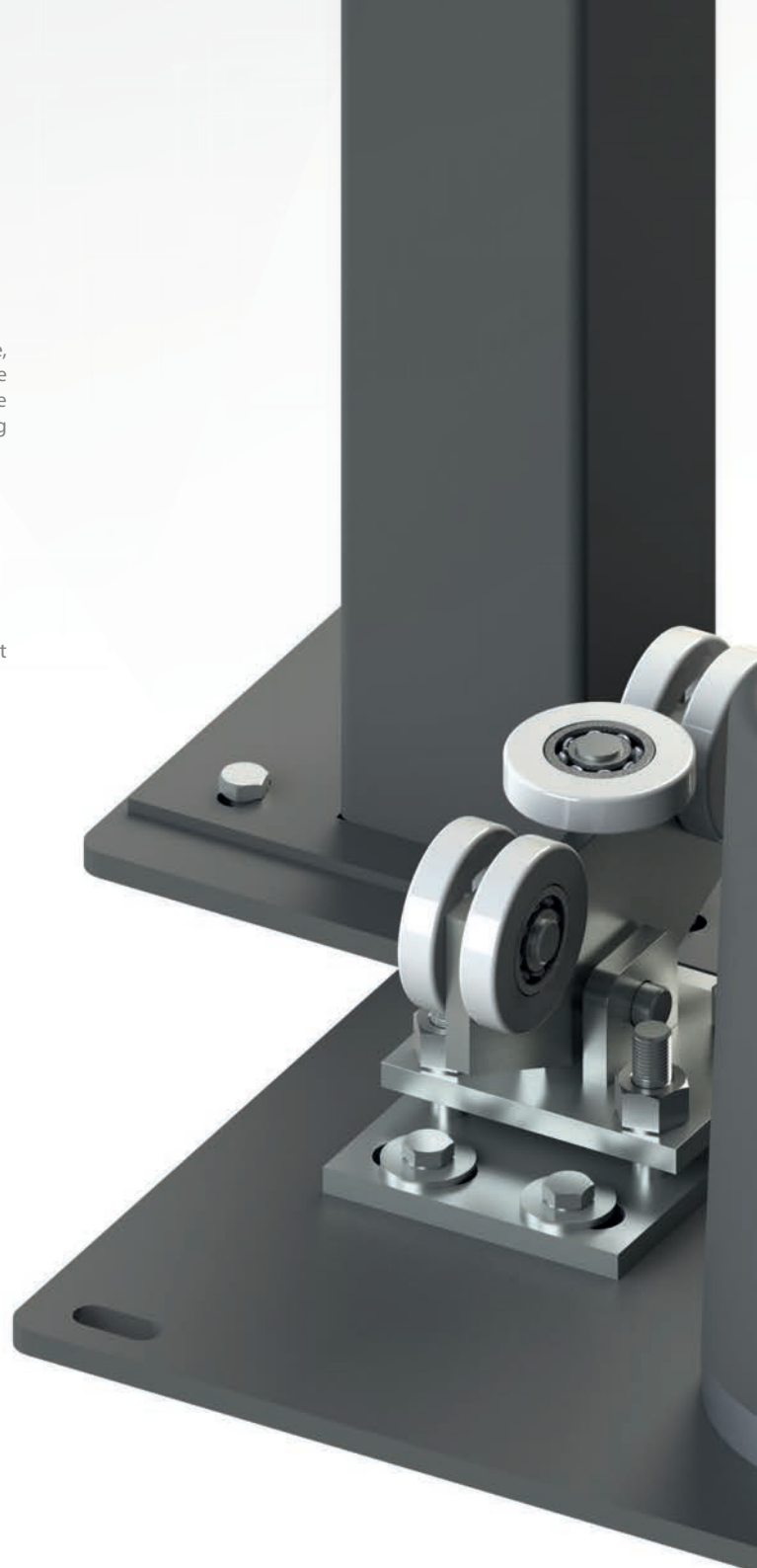

SAFEHOME

Standard

Simplicity, minimalism and classic shapes.
Both the filling of the panels and gates are made of vertical elements.





Steel

EK.20.101

Standard

Double leaf gate | Sliding gate

Fencing system: Wicket, double-leaf gate or sliding gate, segment

Dimension of the beaks: 80x80; 100x100 (Wicket + Gate)

Frame poles: 40x40

Filling profiles: 40x20



Steel

EK.20.102

Standard

Double leaf gate | Sliding gate

Fencing system: Wicket, double-leaf gate or sliding gate, segment

Dimension of the beaks: 80x80; 100x100 (Wicket + Gate)

Frame poles: 80x40

Filling profiles: 80x20

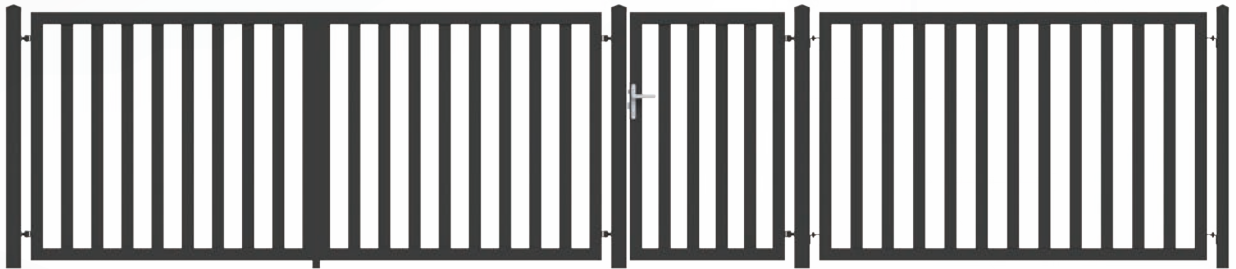

Steel

EK.20.103

Standard

Double leaf gate | Sliding gate

Fencing system: Wicket, double-leaf gate or sliding gate, segment

Dimension of the beaks: 80x80; 100x100 (Wicket + Gate)

Frame poles: 40x40

Filling profiles: 20x20



Steel

EK.20.104

Standard

Double leaf gate | Sliding gate

Fencing system: Wicket, double-leaf gate or sliding gate, segment

Dimension of the beaks: 80x80; 100x100 (Wicket + Gate)

Frame poles: 40x40

Filling profiles: 80x20



SAFEHOME

Elegance

Modern solutions for modern constructions.
The panels are built of horizontal elements.





Steel

EK.20.105

Bestseller

Elegance

Double leaf gate | Sliding gate

Fencing system: Wicket, double-leaf gate or sliding gate, segment

Dimension of the beaks: 80x80; 100x100 (Wicket + Gate)

Frame poles: 80x40

Filling profiles: 80x20

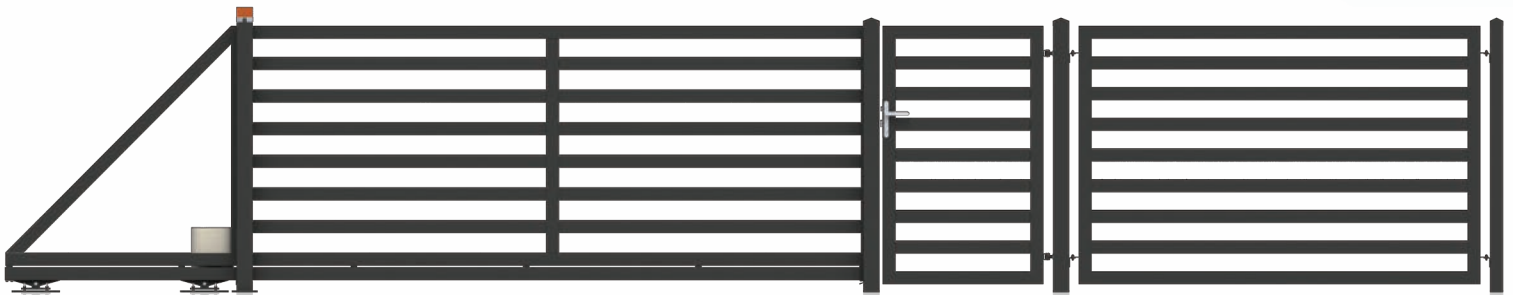

Steel

EK.20.106

Bestseller

Elegance

Double leaf gate | Sliding gate

Fencing system: Wicket, double-leaf gate or sliding gate, segment

Dimension of the beaks: 80x80; 100x100 (Wicket + Gate)

Frame poles: 80x40

Filling profiles: 80x20; 50x20; 30x20

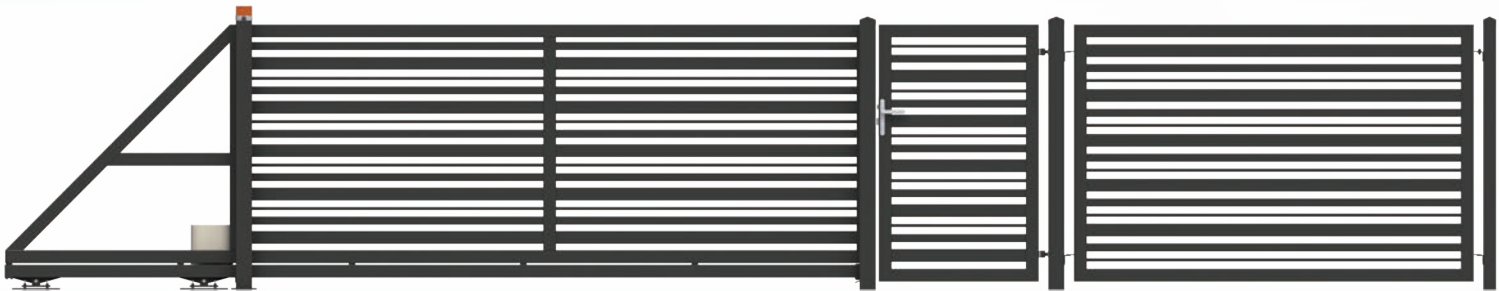
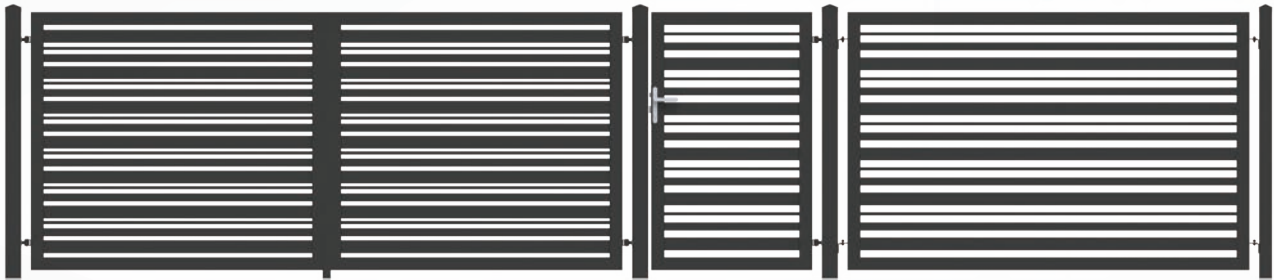

SAFEHOME

Prestige

A sophisticated combination of various shapes in one element.
Fences that not only give a sense of security,
but also become a home decoration.





Steel

EK.20.109

Prestige

Double leaf gate | Sliding gate

Fencing system: Wicket, double-leaf gate or sliding gate, segment

Dimension of the beaks: 80x80; 100x100 (Wicket + Gate)

Frame poles: 60x40

Filling profiles: 100x20; 60x30

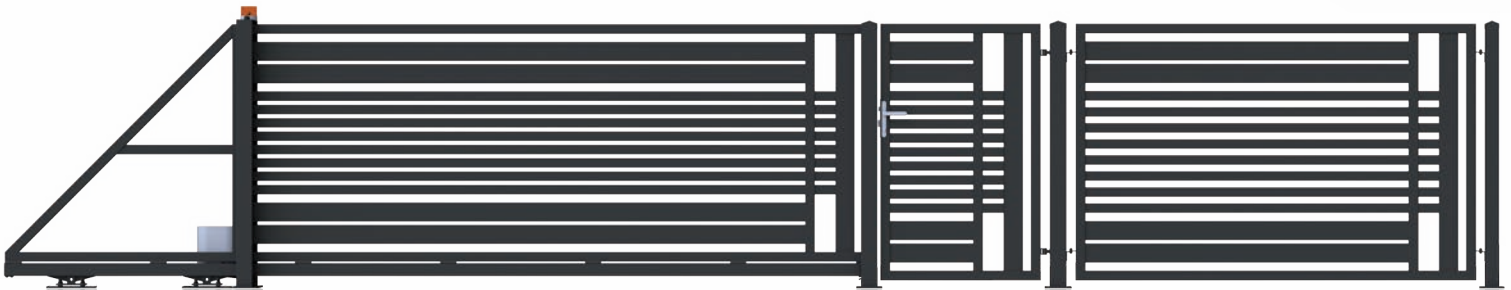
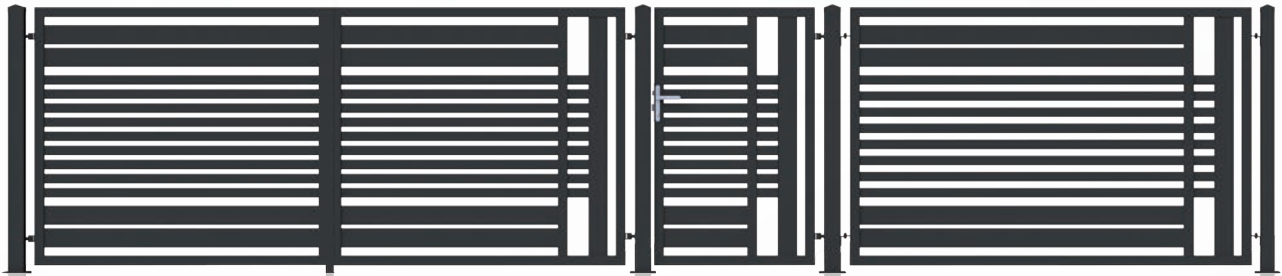

Steel

EK.20.110

Prestige

Double leaf gate | Sliding gate

Fencing system: Wicket, double-leaf gate or sliding gate, segment

Dimension of the beaks: 80x80; 100x100 (Wicket + Gate)

Frame proles: 60x40, 58x44 (Aluminium)

Filling profiles: 80x20; 30x20

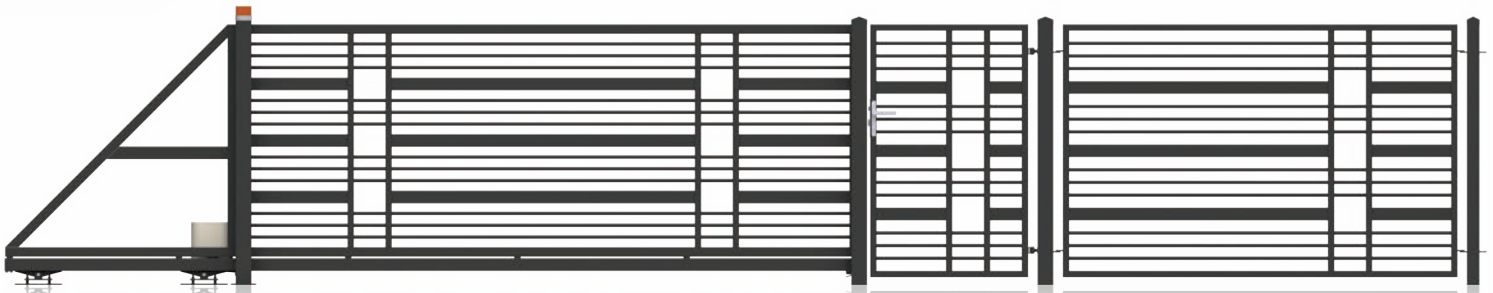

SAFEHOME

ALUMINIUM SPANS

Well known models from the Standard, Elegance and Prestige collection in lighter, aluminum versions.





Aluminium

EK.20.101

Standard

Double leaf gate | Sliding gate

Fencing system: Wicket, double-leaf gate or sliding gate, segment

Dimension of the beaks: 80x80; 100x100 (Wicket + Gate)

Frame proles: 58x44 (Aluminium)

Filling profiles: 40x20

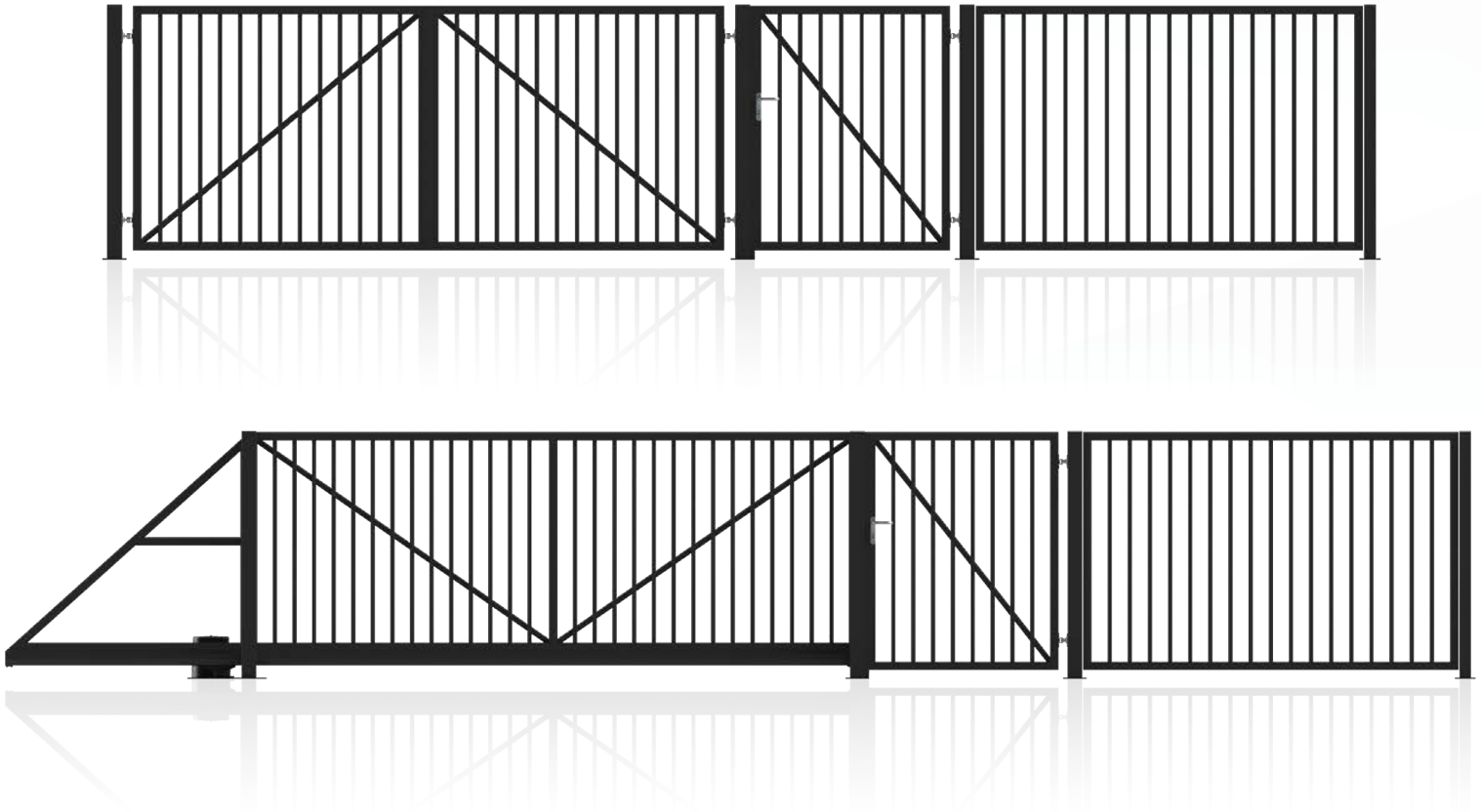

Aluminium

EK.20.102

Standard

Double leaf gate | Sliding gate

Fencing system: Wicket, double-leaf gate or sliding gate, segment

Dimension of the beaks: 80x80; 100x100 (Wicket + Gate)

Frame proles: 58x44 (Aluminium)

Filling profiles: 80x20



Aluminium

EK.20.105

Bestseller

Elegance

Double leaf gate | Sliding gate

Fencing system: Wicket, double-leaf gate or sliding gate, segment

Dimension of the beaks: 80x80; 100x100 (Wicket + Gate)

Frame proles: 58x44 (Aluminium)

Filling profiles: 80x20

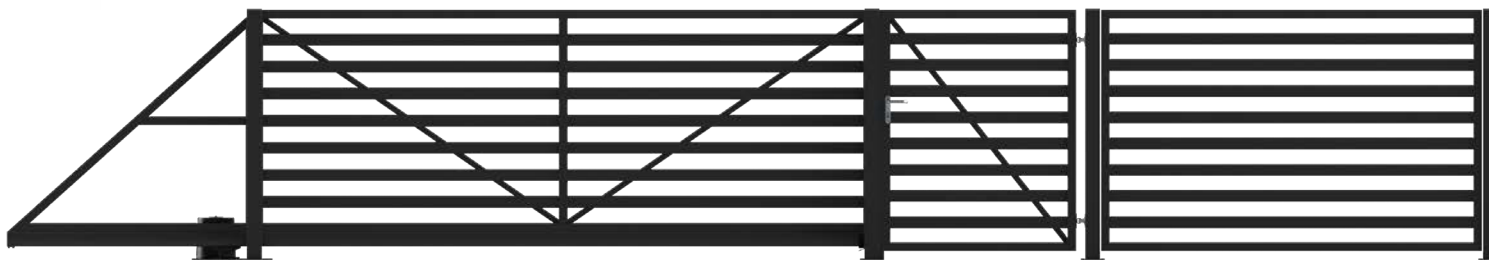
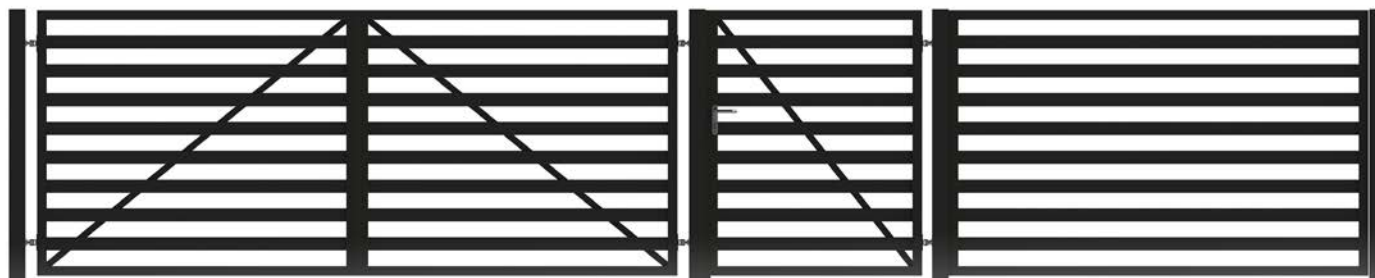

Aluminium

EK.20.106

Bestseller

Elegance

Double leaf gate | Sliding gate

Fencing system: Wicket, double-leaf gate or sliding gate, segment

Dimension of the beaks: 80x80; 100x100 (Wicket + Gate)

Frame proles: 58x44 (Aluminium)

Filling profiles: 80x20; 50x20; 20x20

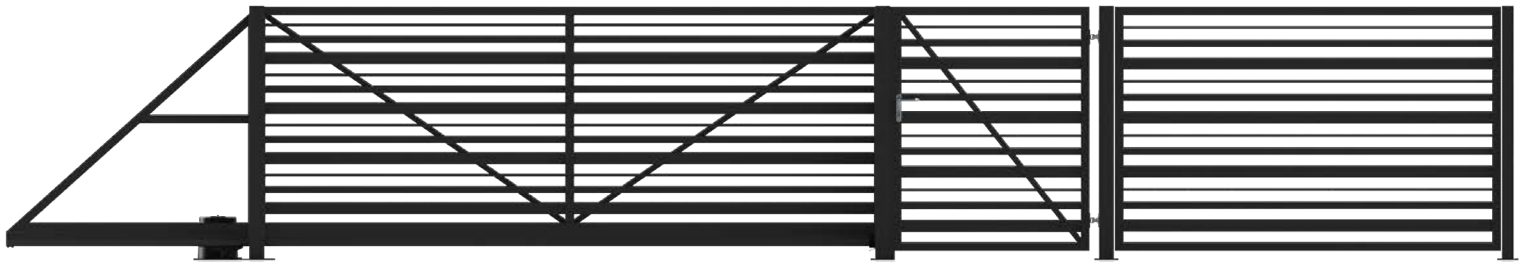
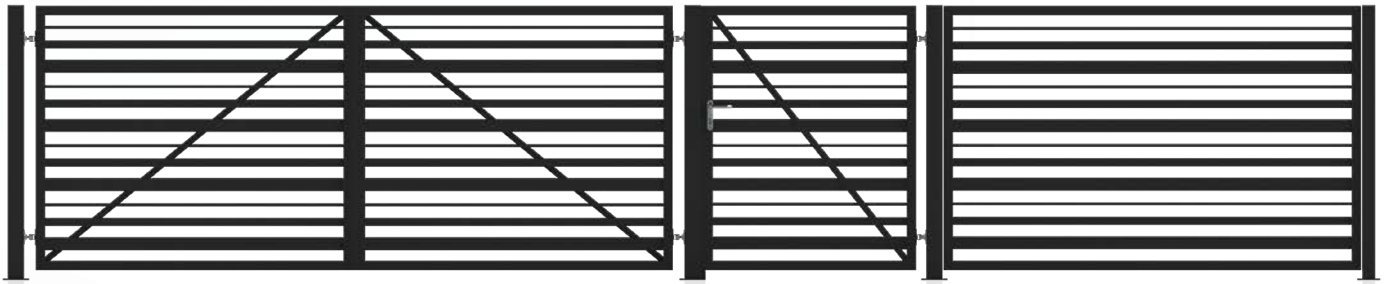

Aluminium

EK.20.108

Elegance

Double leaf gate | Sliding gate

Fencing system: Wicket, double-leaf gate or sliding gate, segment

Dimension of the beaks: 80x80; 100x100 (Wicket + Gate)

Frame poles: 58x44

Filling profiles: Tongue-and-groove locked aluminium panel; tongue height 100 mm

The panel can be inserted oriented vertically or horizontally.



Aluminium

EK.20.109

Prestige

Double leaf gate | Sliding gate

Fencing system: Wicket, double-leaf gate or sliding gate, segment

Dimension of the beaks: 80x80; 100x100 (Wicket + Gate)

Frame proles: 58x44 (Aluminium)

Filling profiles: 120x20; 60x20

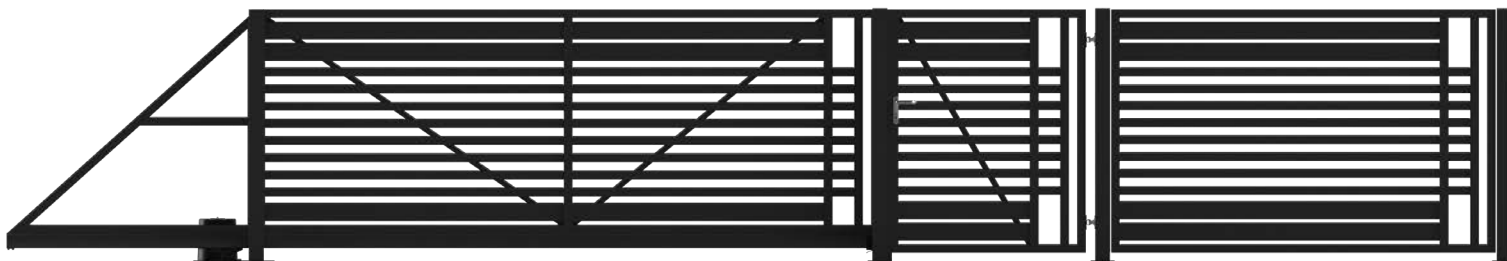
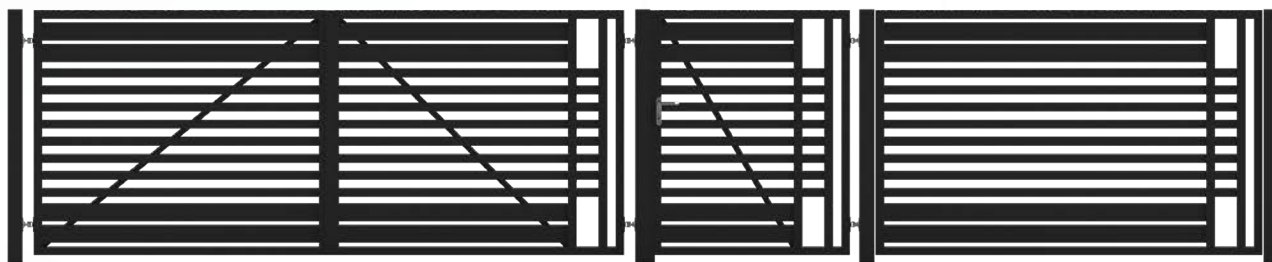

Aluminium

EK.20.110

Prestige

Double leaf gate | Sliding gate

Fencing system: Wicket, double-leaf gate or sliding gate, segment

Dimension of the beaks: 80x80; 100x100 (Wicket + Gate)

Frame proles: 58x44 (Aluminium)

Filling profiles: 80x20; 40x20

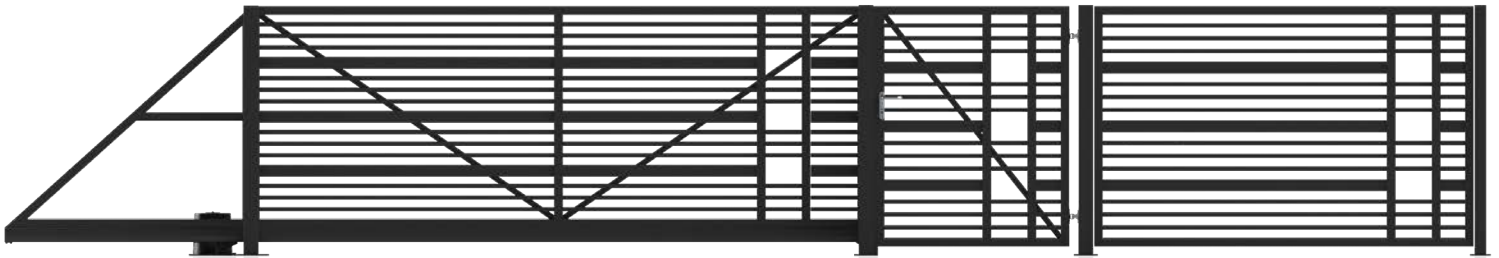
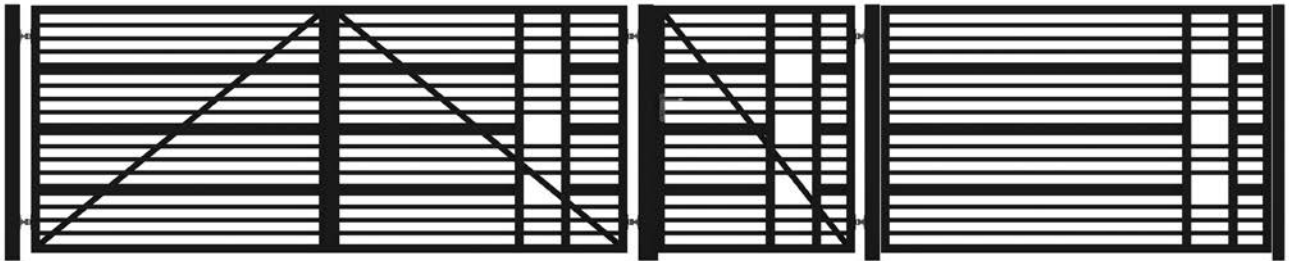

Aluminium

EK.20.111

Prestige

Double leaf gate | Sliding gate

Fencing system: Wicket, double-leaf gate or sliding gate, segment

Dimension of the beaks: 80x80; 100x100 (Wicket + Gate)

Frame poles: 58x44

Filling profiles: Tongue-and-groove locked aluminium panel; tongue height 100 mm

Flat bar: 80x20

The panel can be inserted oriented vertically or horizontally.

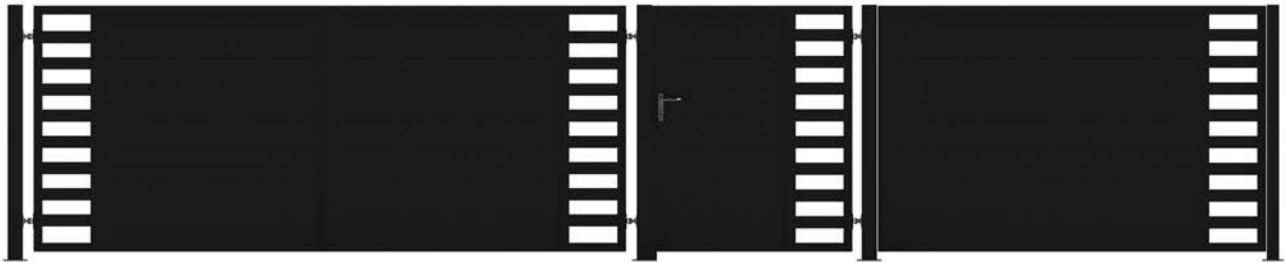

A modern, two-story house with a dark wood or stone facade and large windows. A swimming pool is visible in the foreground, reflecting the house and sky. The scene is set in a bright, sunny environment.

SAFEHOME

INDIVIDUAL DESIGN AND POSSIBILITIES

The gates and wickets of our fences can be equipped with a number of accessories that will make them more functional and easier to use.



HOUSE NUMBER

The house number, which is resistant to weather conditions, can be installed anywhere on the fence - on the post, gate or wicket. We also offer plates with the house number and the street name engraved.

96



MAILBOX

Made of the highest quality materials. Mounted on the post or on the gate. The design of the boxes ensures the security of packages.

+ Mail slot with a front-mounted flap.



HANDLES AND DOOR-PULLS

Wickets, depending on the needs, can be equipped with handles or door-pulls. Our wide offer guarantees that it will fit in with the appearance of the fence.

Available with WALA pull handles.



VIDEO ENTRY PHONES

SOMFY V100

The compact video entry phone with a 4" full colour display enables operation of the driveway gate and the electric lock for the entrance wicket. The 5-channel remote integrated with the internal display monitor allows operation of Somfy RTS-enabled devices.



SOMFY V300

The V300 video entry phone is dedicated for single homes and duplexes. Featuring a 7" full colour internal display monitor, enabling easy management of the driveway gate, the electric lock for the entrance wicket and Somfy RTS-enabled devices, all without having to leave home. The device provides many other functionalities for full access control and operating convenience.



SOMFY V500

V500 is a new generation video entry phone complete with a touch-screen display, a 5-channel RTS remote transmitter and the ability to take pictures of callers. It is provided with a wide-angle entry camera and a LED IR illumination for night-time visibility. With a single touch of the V500 internal display monitor, you can operate multiple Somfy RTS-enabled devices.



DRIVES - Somfy

Double-leaf gates

Elixo Smart io - the most efficient drive to standard installations.

- *Maximum weight / leaf length – 200 kg / 4 m,*
- *Slide of a 3 m wide gate in 15 seconds,*
- *Lack of edge limits,*
- *Easy programming.*



Elixo 500 3S RTS - (in standard to the sliding gate) reliable, resistant and silent drive to the sliding gates. The set include: the drive, 2 Keygo RTS remotes, emergency accumulator, warning light, 2 photocells.

- *Maximum weight / leaf length – 500 kg / 8 m,*
- *Up to 30 cycles per day for gates up to 500 kg weight,*
- *Slide of the 3 m wide gate in 15 seconds,*
- *Easy unlocking and opening the gate from outside,*
- *Possibility to connect a solar panel.*



Possibility to order drive in the io compatible form with all Somfy products working in this technology. Joining to the TaHoma® system enables remote control and control the position in which the gate is.

Double-leaf gates.

Ixengo L 3S RTS - (in standard to the double-leaf gate) strong, effective and safe drive to large gates. The set includes: the drive with the switchboard, 2 Keygo RTS remotes and fastening to the post.

- *Maximum weight / leaf length – 400 kg / 4 m,*
- *Opening time 10 to 34 s, according to installation,*
- *Switchboard 3S: quick installation, possibility to set the work parameters, intuitive service,*
- *Possibility to connect the solar panel,*
- *Not-turning back mechanism provides very good resistance to the strong wind and other energies,*
- *Easy and safety decoupling with the use of individual key.*



Possibility to order a drive in a compatible io version with all Somfy products working in this technology. Joining to the TaHoma® system enables remote control and control of the position, in which the gate is.

NEW ARRIVAL

MULTI - POST

The multi-post fencing perfectly combines with the fence.

It can accommodate an entrance intercom panel, a keypad or a mailbox that is conveniently openable from the inner side. The building number and street name can also be cut out of the post.



DRIVE

The gate can be equipped with a drive, thanks to which the user will be able to control it using the remote control. When connected to the appropriate control units, they can become part of a „Smart Home“.



PHOTOCELLS

The safety of using our gates is guaranteed by photocells. Thanks to them, the gate stops immediately after detecting any obstacles in its path. Installation of photocells in the gate eliminates the risk for vehicle passing through the gate.



SIGNAL LIGHT

Reliable, easy to install warning lamps informing about closing and opening the gate. The huge advantage of our lamps is their hermetic case. Thanks to it, all the elements under the lampshade are resistant to weather conditions.



Fencing installed on steel posts with base feet attached to a foundation structure.



Fencing installed on masonry posts with the spans attached to the base wall.



Fencing installed on masonry posts only.



HOW TO PLAN THE CONSTRUCTION OF FENCES?

The fence should perform its role in the best way possible. Not only its appearance, but also functionality is important. Experience tells us that only an individual approach to each project will give us the guarantee of combining both of these features. Every, even the smallest element of the fence should be planned. This, however, requires taking into account in such issues as the presence of garbage bins, electrical boxes, poles or trees on the property.

POSSIBILITES

The double-sash turn gate is one of the two solutions we recommend. A sufficient amount of space on the driveway is necessary to open it, but the assembly requirements are much lower than for other gates. Doors can be mounted regardless of the terrain, because we have the freedom to maneuver the height of its suspension. The solution is recommended especially in the case of narrow entries.



The sliding gate moves along the fence, and thus, to open it, no additional space is required on the driveway. The great advantage of this solution is also the fact, that after opening the gate we get a full passage. Thanks to photocells, which are installed in a sliding gate as standard, there is no risk of sudden closure and damaging the vehicle. The restriction regarding the installation of the gate is the length of the fence. It must be wide enough for the gate to hide in it.

TAKING EXISTING OBJECTS UNDER THE CONSIDERTION

If there are any obstacles on the property where the fence is installed, it must be taken into account in the project. The most important elements are undoubtedly gas and electricity junction boxes. We need to keep them on permanent access, so they must be situated in the fence line. Nothing prevents us to slightly change the panel structure and adapt it to the individual needs of the customer.

When designing a fence, you should also consider the location of the trash. The easiest and most aesthetic solution is undoubtedly making a recess for a trash container. You can also build it so that it does not attract too much attention. For functional reasons, it is worth placing it near the entrance gate.





INITIAL VALUATION

You can receive the initial offer for the fence within 24 hours from the date of submitting the inquiry. The pricing will include the quantity and price of material necessary for the construction of the fence (number of panels, gate, wicket, accessories).



CUSTOMER ACCEPTANCE

If you accept all the conditions we offer, then the order will be forwarded for production. We offer the shortest delivery time. We will provide fences from the Standard Line within just 6 weeks.



FINAL VALUATION

You will receive the final price after 3 days from the acceptance of the initial conditions of the contract. The valuation will be fully personalized and adapted to customer requirements and terrain (notches for boxes, trees, garbage containers).



5-year commercial warranty included. The fencing systems are available in any RAL palette color (in flat, semi-flat, glossy or textured finish).
The fencing is provided with spacers for easy assembly.

The publication does not constitute a commercial offer. It is not a basis for submitting complaints.
Presented photographs are illustrative pictures, not actual product photos.

1/2021



Eko-Okna S.A.

ul. Spacerowa 4

47-480 Kornice

www.ekookna.com